

Graphic Design

BRINGING YOUR VISION TO LIFE

A major strength of Safety Research Corporation of America (SRCA) is its ongoing delivery of exceptional graphic design services that communicate an idea or message, assist in educating a targeted audience, or make an organization's identity more recognizable. Creativity and originality is conveyed through SRCA's professional portfolio comprised of a wide array of resources to include technical publications, brochures, catalogs, user manuals, presentation materials, and posters. With 40 years of combined experience in strategic layout and placement of graphics, text, and illustrations, SRCA is able to artfully combine the benefits of creative graphic applications with the written word.

SRCA also creates free-hand drawings and illustrations in various media with a broad range of audiences in mind. Various supportive solutions are also produced by SRCA to include interpretive graphics, high-end videos, and 3D graphical animations. With backgrounds in industrial design, fine arts, illustration, photography and graphic design, SRCA's creative staff will ensure that the visual impact and meaning of all design materials are communicated effectively, creatively and responsibly.

WEBSITE/PORTAL DESIGN

When it comes to website design or portal development, SRCA provides engaging products that are easy to understand and create long-lasting impressions. Vibrant and unique web designs are created with a discerning eye for color and placement, as well as quick turnaround times to support your promotional efforts. Excelling in strategic layout, combined with the benefits of creative graphic applications, database integration, site security, and electronic commerce, SRCA develops websites that will successfully communicate your message and capture the targeted audience.



BEFORE

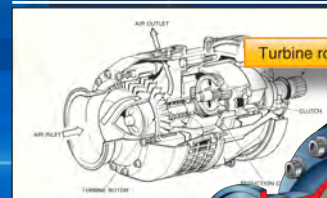

AFTER

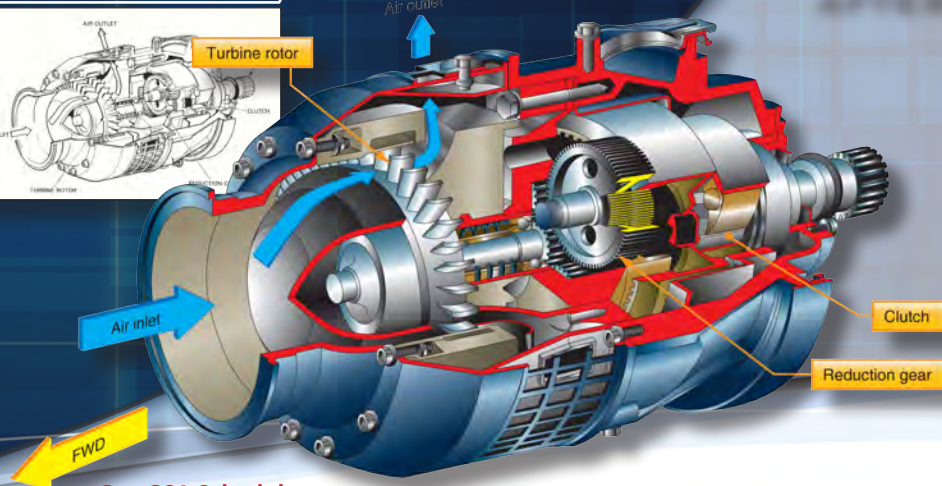

Our GSA Schedules:

SRCA covers a wide array of products and services, including software development, graphic design, training services and safety and operational support.

Contract: GS-00F-0031Y
Contract: GS-00F-0032Y

- Advertising & Integrated Marketing Solutions (AIMS) (541)
- General Purposes Commercial Information Technology Equipment Software and Services (IT) (70)
- Mission Oriented Business Integrated Services (MOBIS) (874)

Safety Research Corporation of America
133 Research Lane
Dothan, Alabama 36305

Director of Business Development: Mrs. Anita Flowers
Cell: (334) 470-6509
Email: aflowers@srca.net



www.srca.net

